



Welcome to your Smart Connection Box

- 1 Status Lights
- 2 Setup Pairing Button
- 3 Output Test Button
- 4 5A Fuse
- 5 Terminal Blocks
- 6 Wire Clamping Area
- 7 Actuator Cable Channel
- 8 DIN Mounting Rail Clamp
- 9 Wall Fixing Holes
- 10 Antenna

Quick install guide

- A. First ensure your choice of Hub is set up and your App is installed.
- B. Mount Connection Box near manifold
- C. Connect actuators to terminal **5**
- D. Connect power, pump and heating source
- E. Launch your App and choose **Devices**, then **Add device** and choose **Smart Connection Box**.
- F. Hold the Setup Button **2** and wait until it shows the device has been successfully paired.
- G. Configure Your installation in App

For more information please visit:
www.wundasmart.com/support

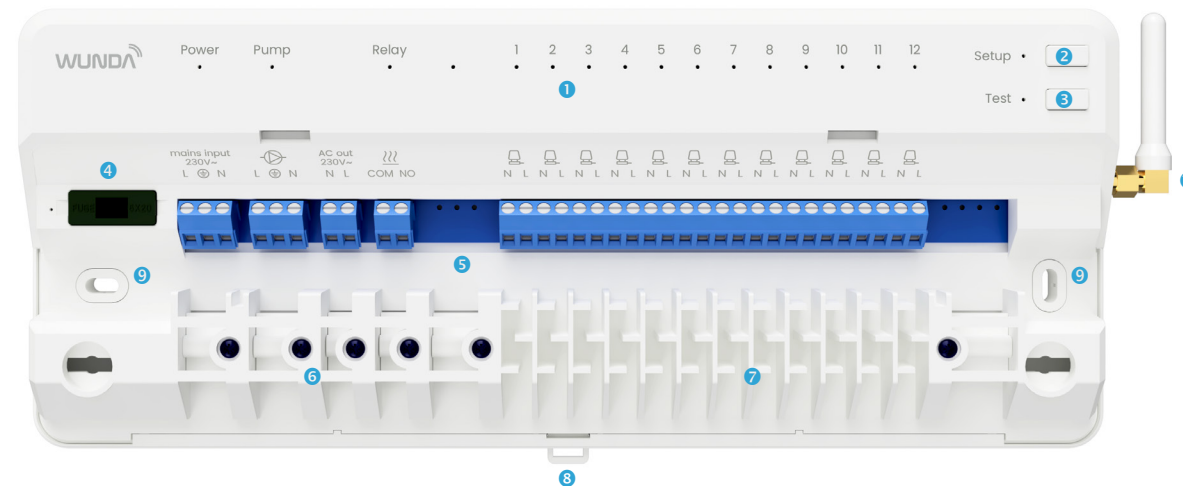

Need our help?

Our designated support staff are on hand to answer all your questions



help@wundasmart.com



0800 083 2677

WUNDA

Welcome to WundaSmart

Technical Specification

Dimension	326 × 133 × 32 mm
Weight	490 g
Power Supply	230V~ 50Hz
Mounting:	DIN rail 35mm
Wiring:	Fixed wiring only
Fuse:	5A
Switch Rating	2(1)A 230V~
Pump circuit load:	2(1)A 230V~
Thermoelectric actuator circuit load:	12x 230V~ 50Hz/20W max
Ingress Protection:	IP20
Operating Temperature	0°C to 45°C
Storage Temperature	-10°C to 55°C
Ambient Humidity	Operating 25% to 90%, Storage 15% to 95% (non-condensing)
Software Class	A
Rated Impulse Voltage	2.5kV
Radio SRD Frequency	869.85 MHz
Radio SRD Bandwidth	125 kHz
Radio SRD Maximum Power	< 5 dBm

EU Declaration of Conformity

This device is in compliance with essential requirements and other relevant provisions of the following EU Directives:

- RED Directive 2014/53/EU
- RoHS Directive 2011/65/EU

A copy of the EU Declaration of Conformity is available at: wundasmart.com/conformity



Precautions

1. Installation and connection should be carried out by technical service or authorized and qualified persons according to applicable regulations and standards.
2. Always disconnect the power supply when connecting or disconnecting the devices powered from the main device.
3. Before the installation, read the terms and conditions of the warranty and these instructions. Improper installation or use against these instructions will void the warranty.
4. All repairs to the device should be carried out by a competent electrician. Otherwise, it will void the warranty.
5. This device should not be installed or worked on by minors, people with reduced physical or mental abilities or with lack of experience or knowledge of the equipment, except if supervision and instruction for the safe use of the equipment is provided in such a manner that all the associated hazards are understood.
6. If a power cord is damaged, it should be replaced by a qualified person in order to avoid a hazard.
7. Do not install the device with mechanically damaged casing or damaged/broken cables.
8. The device must not be exposed to water or excessive humidity resulting in steam condensation (e.g. caused by rapid changes of the ambient temperature).

The WEEE symbol means that a device must be disposed of separately from general household waste. When a device reaches the end of its life-span, it must be taken to a designated waste collection point for safe disposal or recycling.

This conserves natural resources, protects human health and helps the environment.



Manufacturer

WundaGroup PLC
Caldicot, NP265AD
United Kingdom
www.wundasmart.com

Heating Source - Voltage Free (wiring example)

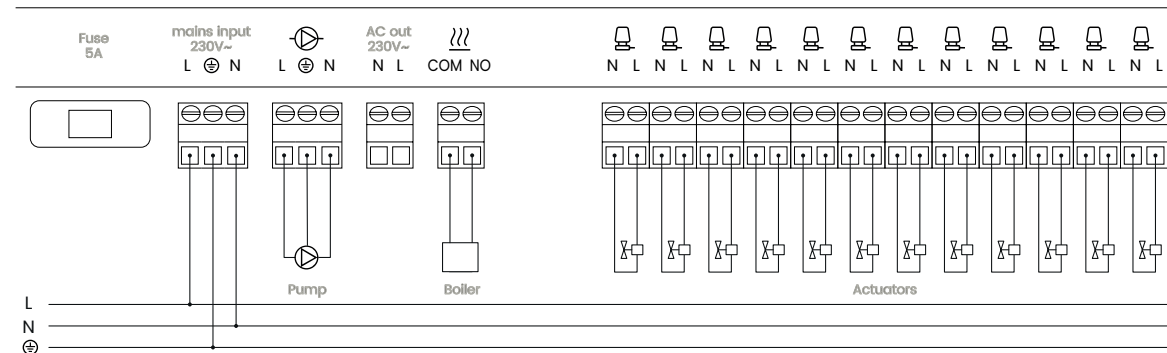

Heating Source - 230V~ Output (wiring example)

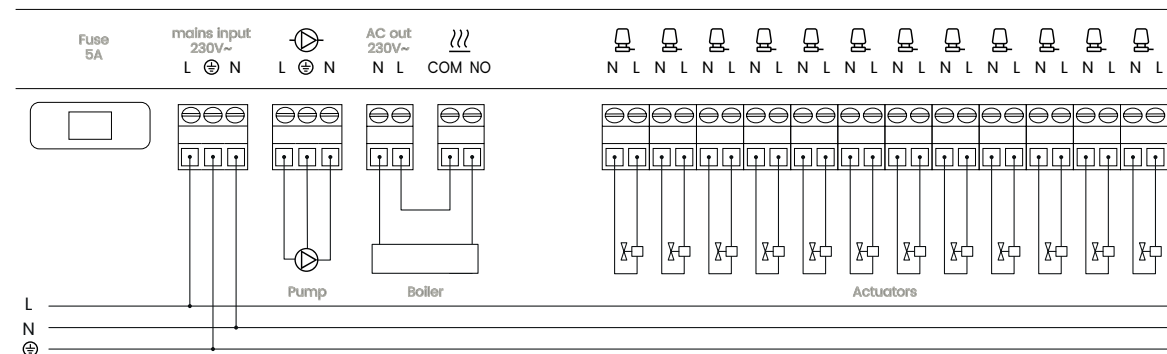

If you are wiring your two port valve or direct feed to trigger the boiler to the connection box, ensure that you select the relay within the app when you are selecting your actuators.

